



VATAYANAM
Sleek designs, high performance



V-TECH BUILDING SYSTEMS PVT. LTD.

Head Office & Experience Centre:

No. 693, M.N.S. Arcade, East Facing, 1st & 3rd Floor,
Dr. Rajkumar Road, 6th Block, Rajajinagar,
Bengaluru - 560 010. | Ph. : 080-23101277
Cell : +91 99801 11468, 97404 22863
E-mail: vtechbuildingsystems@gmail.com
Web: www.vtechwindows.com / www.vtechfacade.com

Works:

UNIT-1 :
No. 162/1, N.S.R. Complex, East Facing,
Beside ICTS, Kalenahalli, Shivakote,
Hesaraghatta, Bengaluru - 560 089.

UNIT-2 :
No. 150, East Facing, Beside ICTS,
Kalenahalli, Shivakote,
Hesaraghatta, Bengaluru - 560 089.

VATAYANAM

VATAYANAM
Sleek designs, high performance

ADVANCED
ALUMINIUM
WINDOWS
AND
DOORS

SLEEK DESIGNS, HIGH PERFORMANCE



V-TECH BUILDING SYSTEMS PVT. LTD.

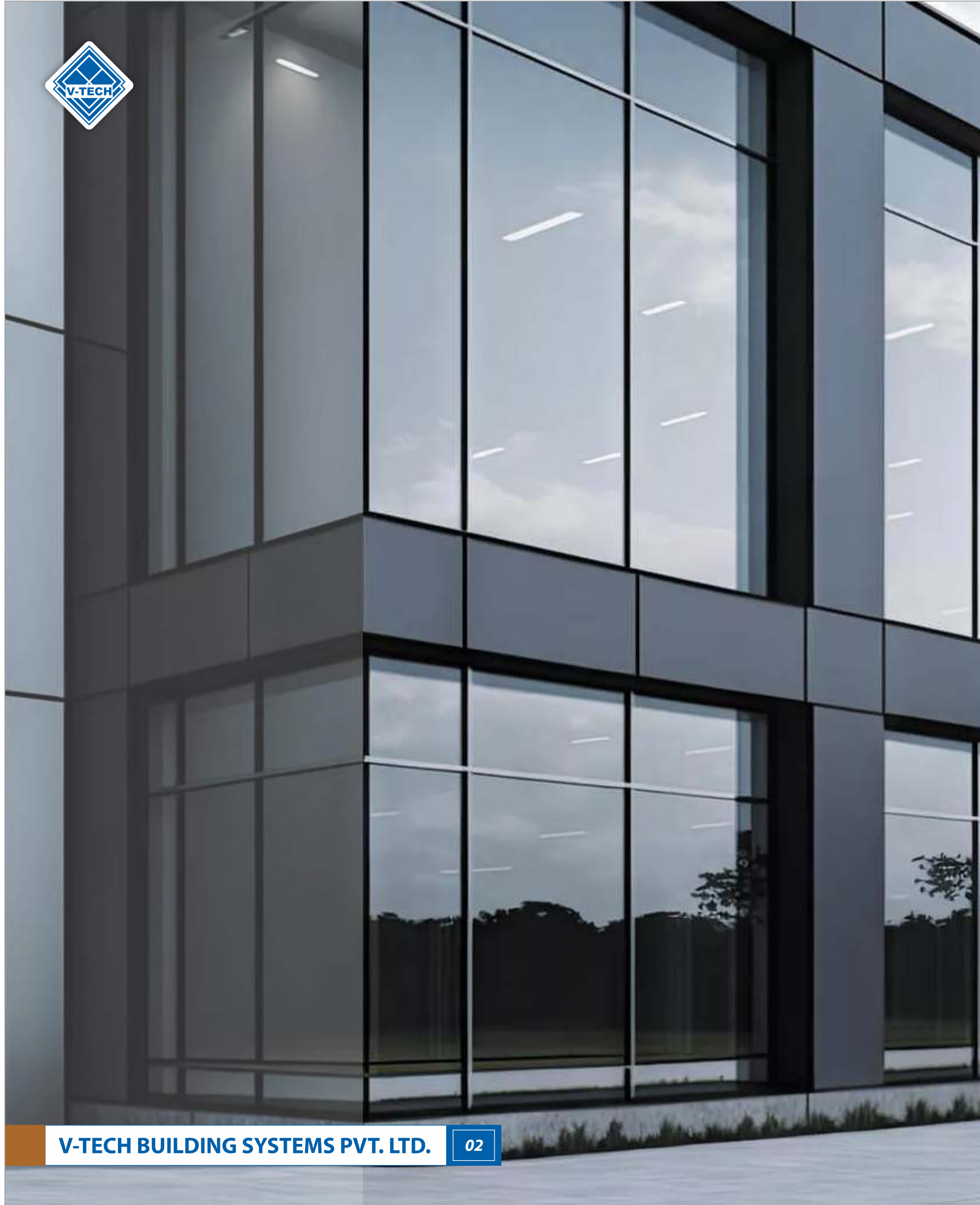

OVER VIEW

V-Tech Building Systems Private Limited, established in 2012, specializes in manufacturing uPVC windows and doors, having successfully completed numerous projects with a team of over 150 professionals.

Our state-of-art manufacturing facility is capable of producing up to 100 windows per day, adhering to stringent quality standards.

Our commitment to delivering top-quality products on time has been the cornerstone of our success. As our business evolved, we partnered with Fundermax, an industry leader in high-pressure laminates (HPL) for cladding and Wesmarc for premium rebated engineered wood doors.

Recognizing the market's growing demand for System Aluminium solutions, V-Tech, backed by extensive experience in façade and fenestration, has ventured into the production of high-quality, sleek aluminium windows and doors. VATAYANAM with a dedicated facility and a team of experienced professionals, we are committed to delivering the finest System Aluminium windows in the industry.

VATAYANAM is continuing companies legacy of excellency in the façade and fenestration industry.



VATAYANAM

VATAYANAM is a vibrant and forward-thinking company, specializing in premium aluminium windows and doors manufacturing. With a focus on innovation, it leverages the latest advancements in façade and fenestration technology to provide high-performance solutions for modern architectural needs.

Despite being a young company, VATAYANAM operates with a commitment to excellence, ensuring no compromise in the quality and functionality of its products. The company's offerings are designed to deliver a comprehensive range of benefits that meet the highest industry standards. These include superior sound insulation, which significantly reduces external noise, making it ideal for urban environments.

VATAYANAM's products are engineered to withstand high wind loads, ensuring durability and safety even in harsh weather conditions. They are also water-tight, preventing leaks and ensuring long-lasting performance. With high air permeability, the products contribute to energy efficiency by maintaining optimal indoor temperatures. Additionally, they are impact-resistant, adding another layer of protection and durability.

What sets VATAYANAM apart is its ability to blend these functional advantages with cutting-edge aesthetics. The result is sleek, modern window and door systems that not only perform exceptionally but also enhance the visual appeal of any building. This fusion of performance and design is the hallmark of VATAYANAM's approach.

VATAYANAM
Sleek designs,
high performance



HAPPINESS IS THE BIGGEST WINDOW A HOUSE CAN EVER HAVE!

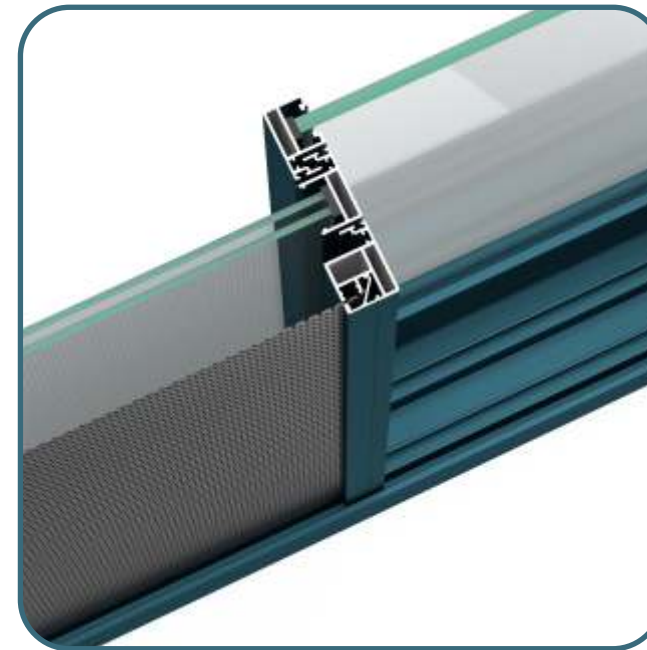
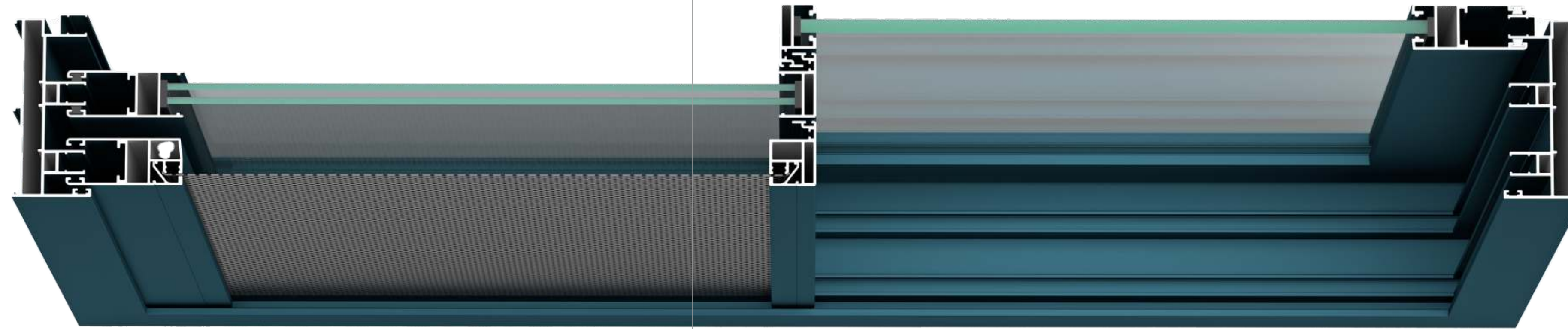

Opal VATAYANAM

Sleek designs, high performance

The "Opal" series by Vatayanam focuses on delivering elegant System Aluminium windows, combining style and performance to enhance the overall aesthetic appeal while maintaining the high-quality standards Vatayanam is known for.

KEY FEATURES

- European design, 25mm Slim Series
- Window Height 2300mm (max)
- Glazing from 5mm to 18mm
- Smooth & Effortless in Movement
- Automatic, Manual Concealed & Multipoint Lock System
- Provision for Insect Screen
- Reinforced Profile Available in Larger Opening
- Design for Mid to Large Size Shutter Sliding
- Bug & Bugler Proof Windows
- Slim Interlock Shutter Available for Single Glass & Double Glass Sliding

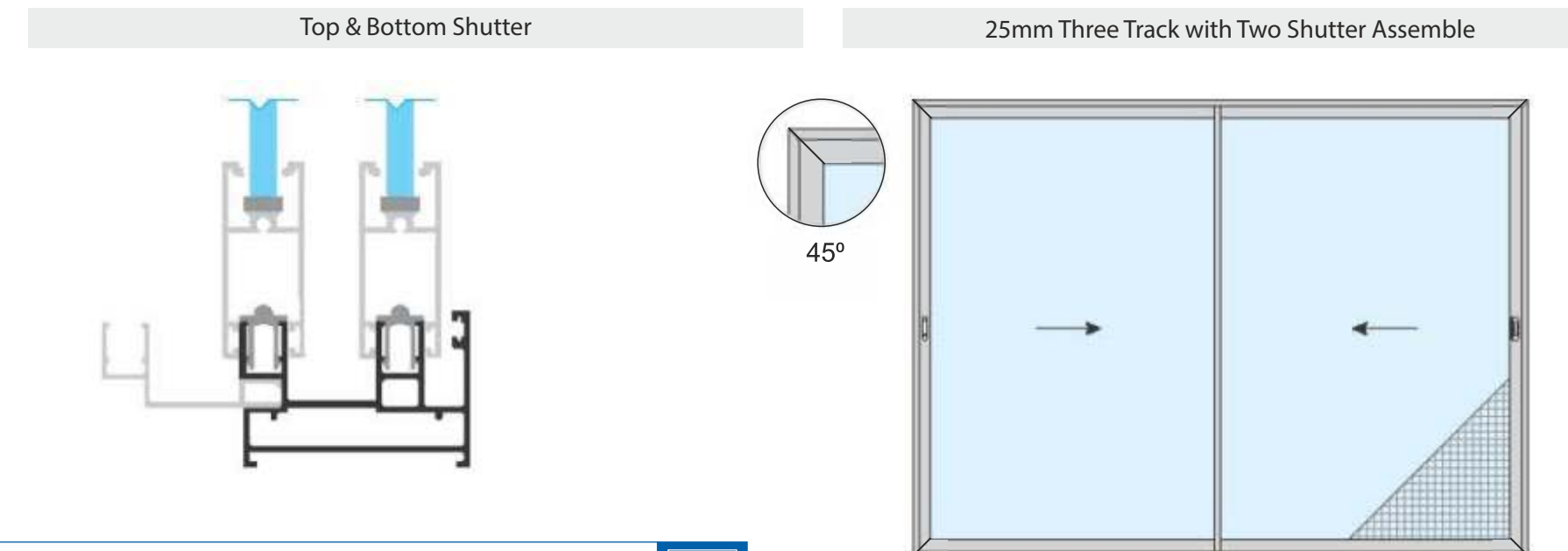
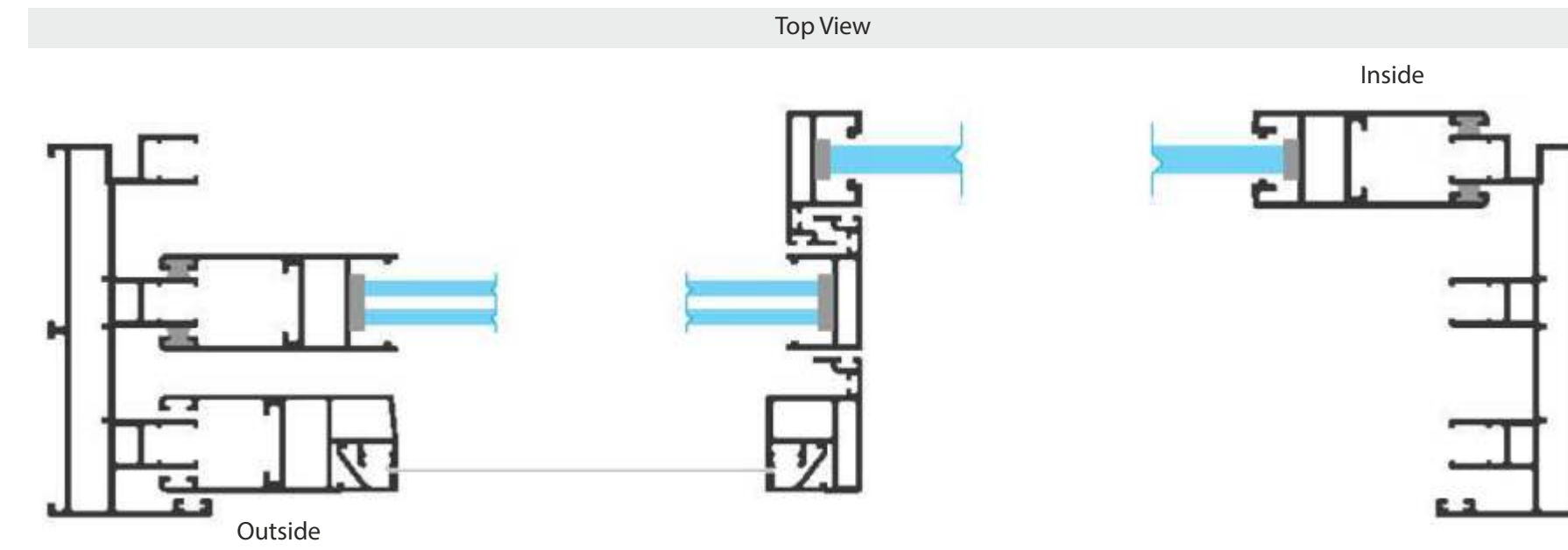
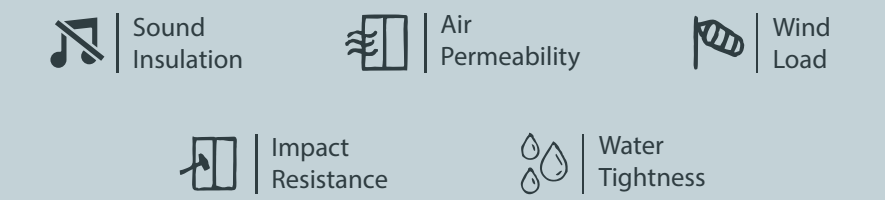



‘**WINDOWS**
BREATHE LIFE INTO SPACES,
FILLING THEM WITH
LIGHT AND **DREAMS.**’



Ruby **VATAYANAM**
Sleek designs, high performance

#superslimseries

The "**Ruby**" series from Vatayanam offers very slim aluminium window systems that maintain a sleek aesthetic while being robust in functionality, ensuring both style and durability.

TECHNICAL CHARACTERISTICS

Window Height (Max)
2300mm (up to 7.5ft)

Sash Height & Width
62mm / 25mm

Interlocking

- Slim Interlock 20mm
- Without Slim Interlock 65mm

Track Option

- 2 Track
- 3 Track
- 4 Track

Track Depth

- 2 Track Top/Bottom 28mm/72mm
- 2 Track Vertical 13mm/76mm
- 3 Track Top/Bottom 28mm/112mm
- 3 Track Vertical 13mm/114mm
- 4 Track Top/Bottom 28mm/145mm
- 4 Track Vertical 13mm/149mm

Glass Range

- Single Glass Sash 5 to 8mm
- Double Glass Sash Upto 18mm

Corner Joint

- Track Joint 90 Degree
- Sash Joint 45 Degree
- Sash Joint 90 Degree
- Slim Interlock 90 Degree

Roller

- Fix Single Roller
- Fix Double Roller
- Adjustable Double Roller

Locking Options
Single Point & Multipoint

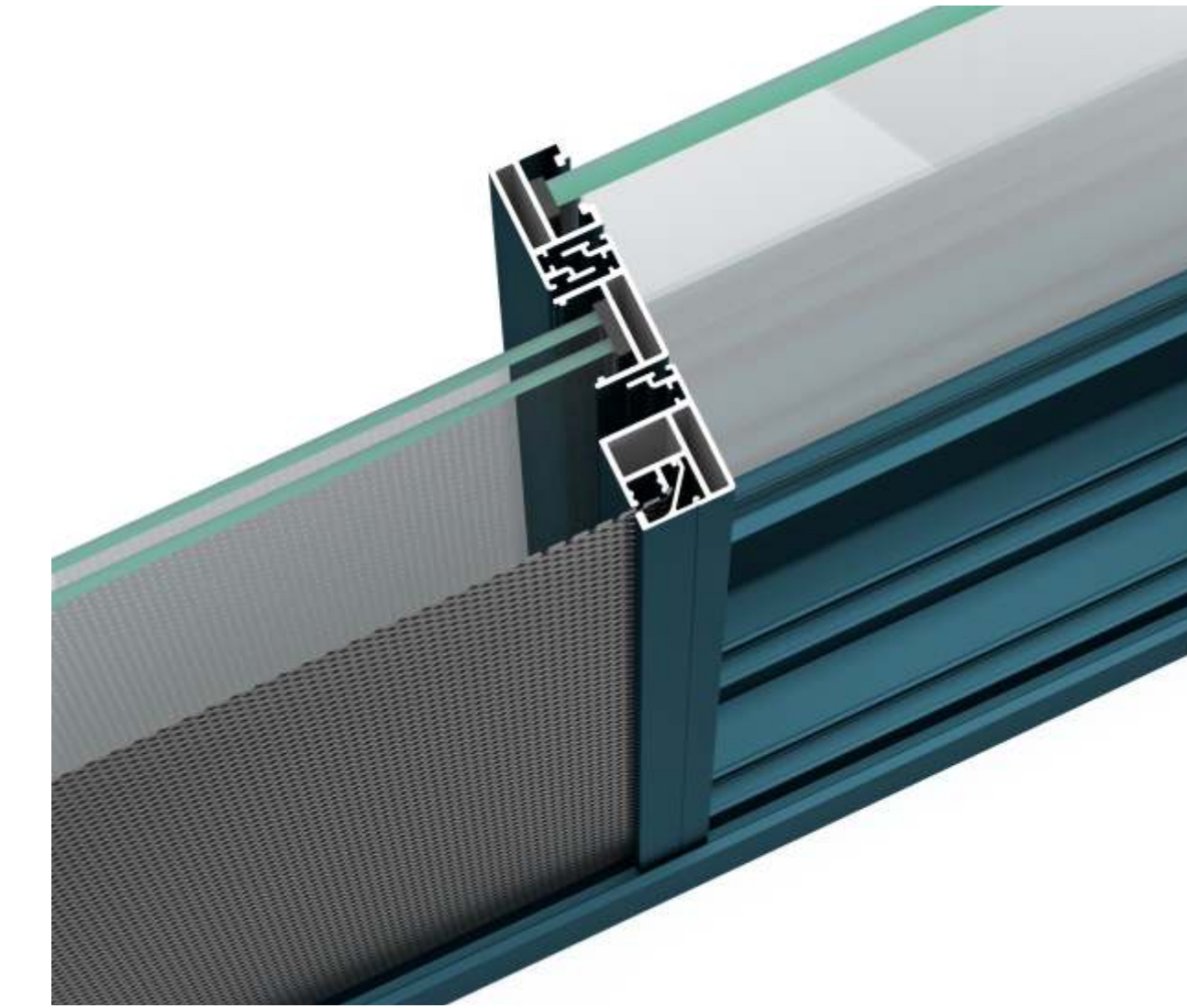

Top View

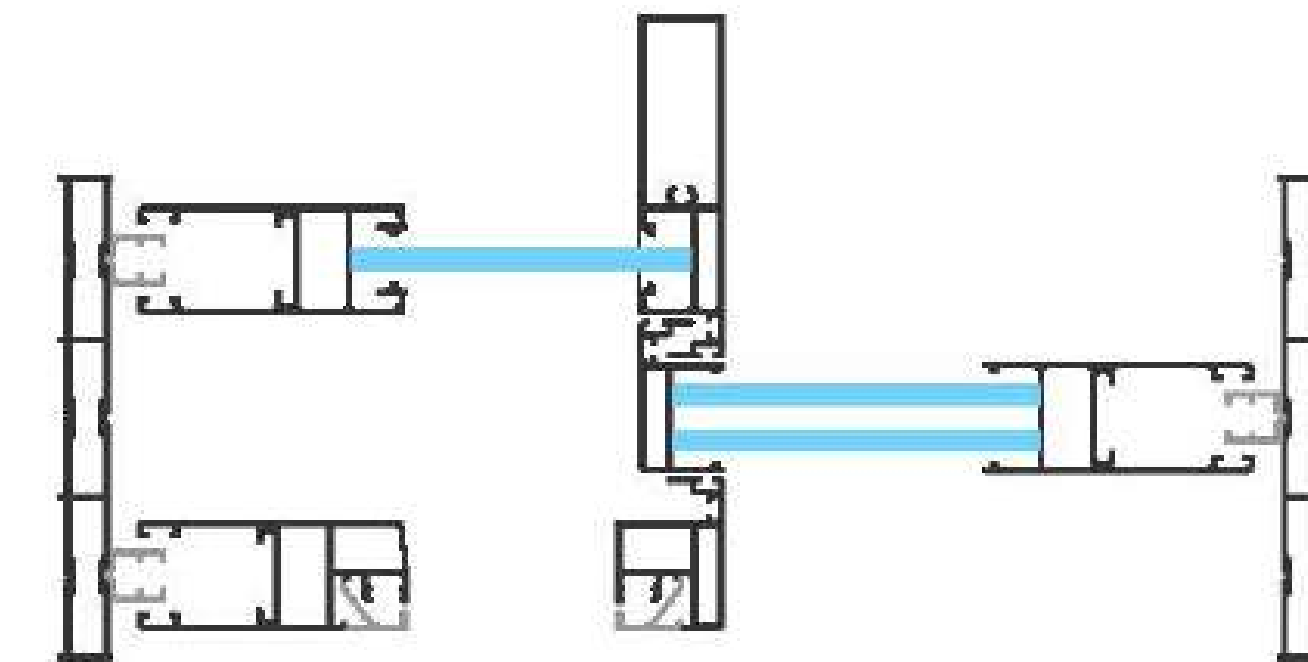

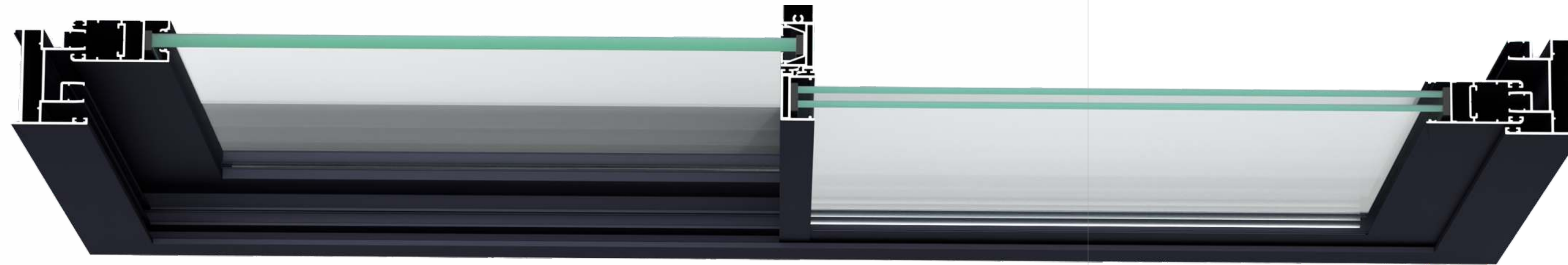

DOORS INVITE
THE SOUL OF
A SPACE TO
EMBRACE THE OUTSIDE
WORLD.



Sapphire **VATAYANAM** Sleek designs, high performance

The "Sapphire" series from Vatayanam offers a slim intermediate design, making it a preferred choice for those who seek a balance between strength and a sleek, slim profile.

TECHNICAL CHARACTERISTICS

Window Height (Max)
2700mm (up to 9ft)

Sash Height & Width
65mm / 29mm

- Interlocking**
- Slim Interlock 18mm
 - Slim Interlock 22mm
 - Slim Interlock 28mm
 - Without Slim Interlock 71mm

- Track Option**
- 2 Track
 - 3 Track
 - 4 Track

- Track Depth**
- 2 Track Top/Bottom 27.3mm/72mm
 - 2 Track Vertical 13mm/76mm
 - 3 Track Top/Bottom 28mm/109mm
 - 3 Track Vertical 13mm/114mm
 - 4 Track Top/Bottom 28mm/145mm
 - 4 Track Vertical 13mm/149mm

- Corner Opening**
- Possible

- Glass Range**
- Single Glass Sash 5 to 8mm
 - Laminated Glass Sash 11 to 15mm
 - Double Glass Sash Upto 22mm

- Corner Joint**
- Track Joint 90 Degree
 - Sash Joint 45 Degree
 - Slim Interlock 90 Degree

- Roller**
- Fix Single Roller
 - Fix Double Roller
 - Adjustable Double Roller

- Locking Options**
- Single Point & Multipoint

Top View

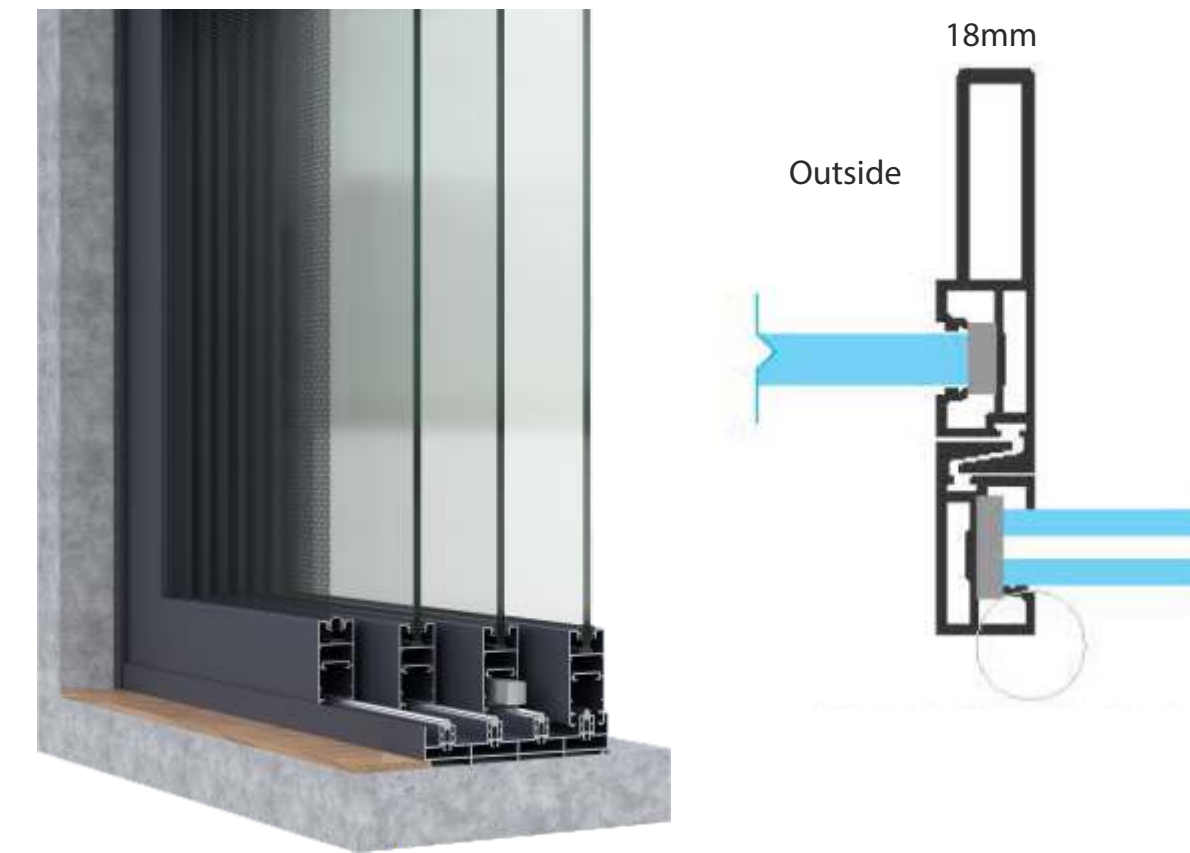

KEY FEATURES

- European design, 29mm Slim Series
- Glazing from 5mm to 24mm
- Smooth & Effortless in Movement
- Automatic, Manual Concealed & Multipoint Lock System
- Provision for Insect Screen
- Reinforced Profile Available in Larger Opening
- Design for Mid to Large Size Shutter Sliding
- Bug & Bugler Proof Windows
- Slim Interlock Shutter Available for Single Glass & Double Glass Sliding

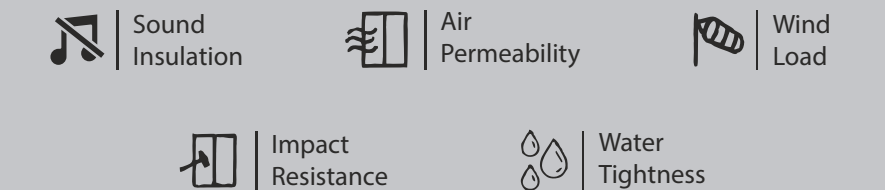



FOLLOW YOUR BLISS AND THE UNIVERSE WILL OPEN DOORS WHERE THERE WERE ONLY WALLS.

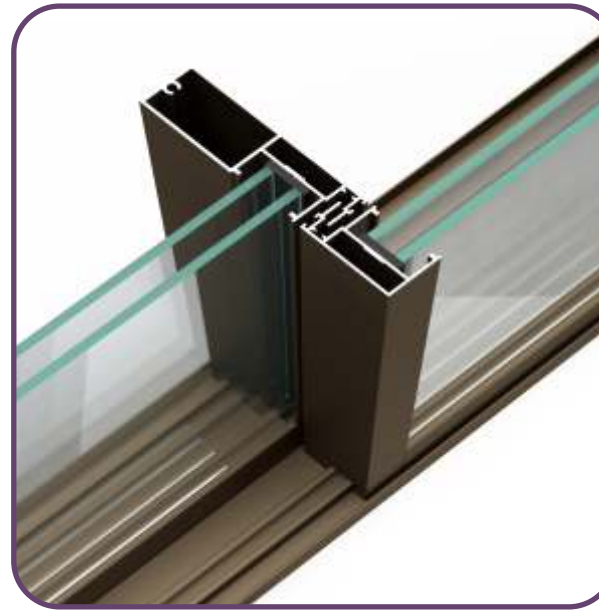
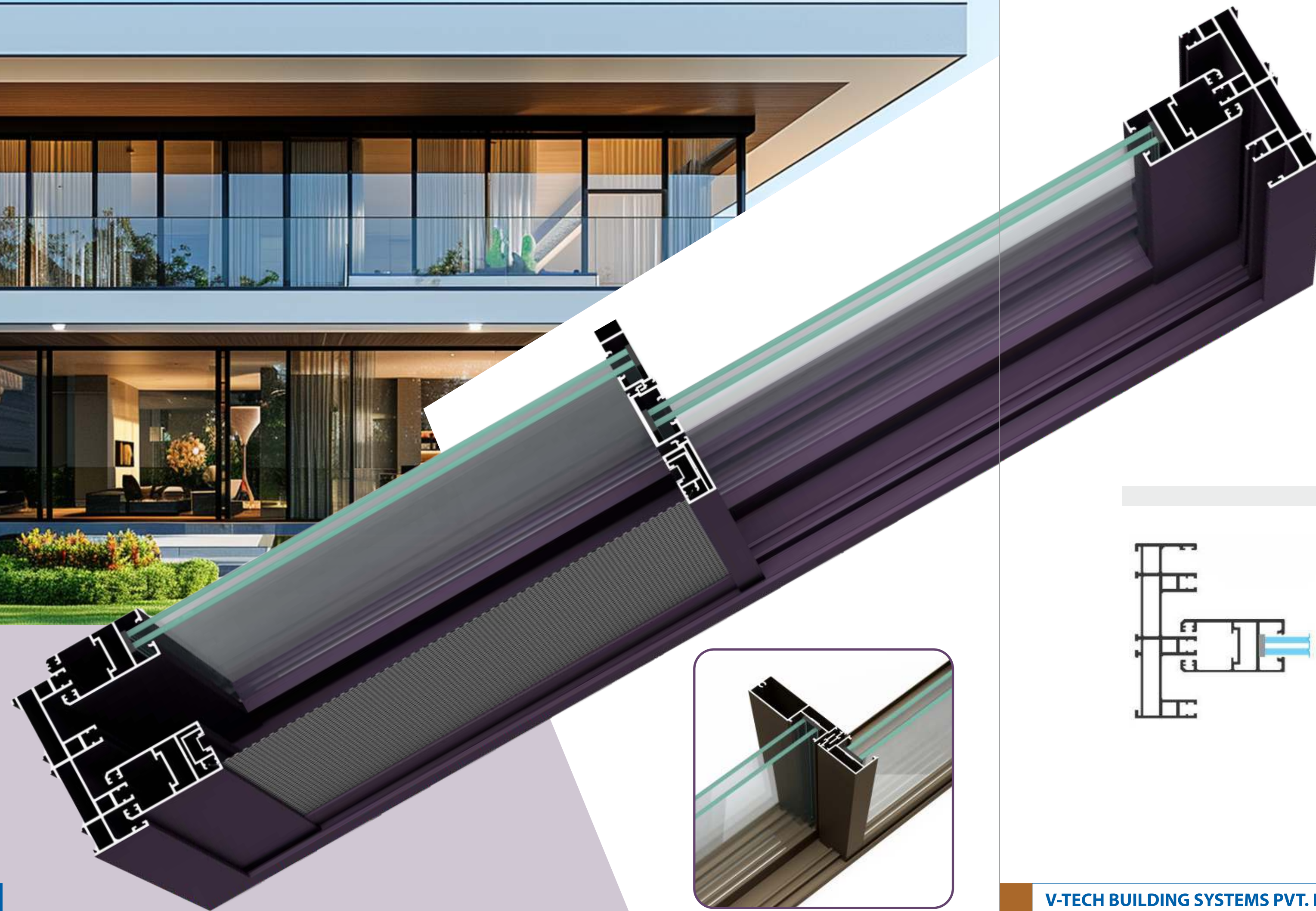

Pearl VATAYANAM

Sleek designs, high performance

The "Pearl" series from Vatayanam offers architects the flexibility to overcome size limitations in window schedules, allowing for greater design freedom without compromising on sleekness or durability.

Three Track with Mosquito Assemble

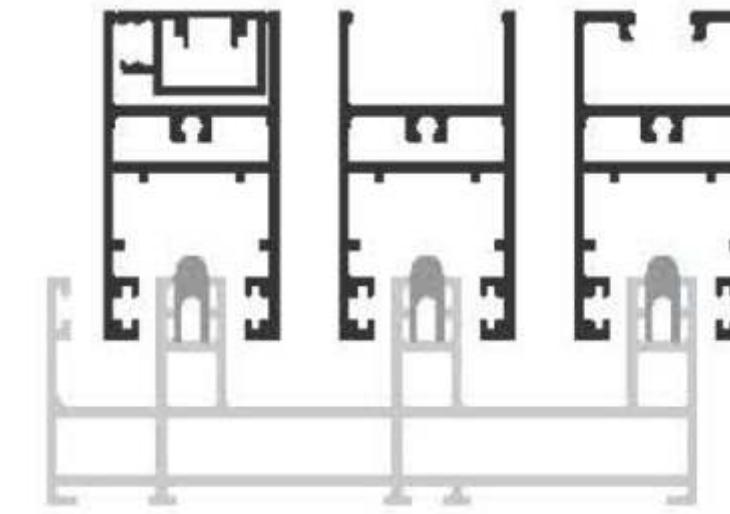

Top View

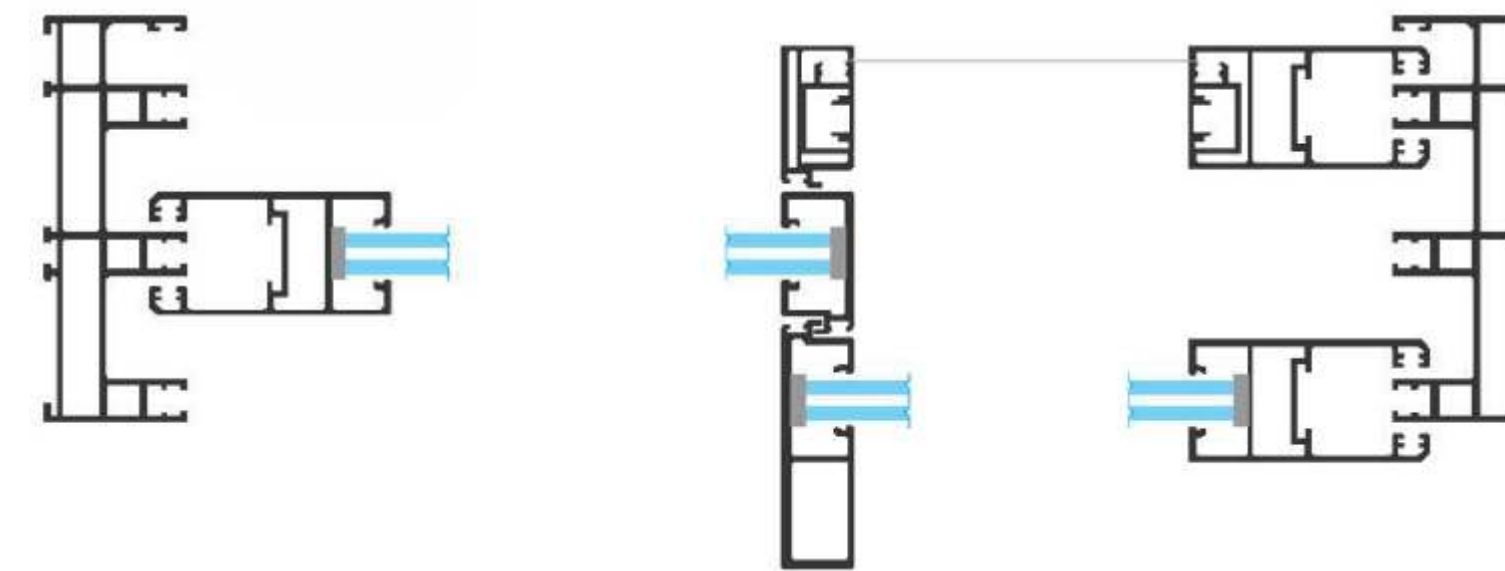

KEY FEATURES

- European design, 35mm Slim Series
- Window Height 3660mm (max)
- Glazing from 5mm to 24mm
- Smooth & Effortless in Movement
- Automatic, Manual Concealed & Multipoint Lock System
- Provision for Insect Screen
- Reinforced Profile Available in Larger Opening
- Design for Mid to Large Size Shutter Sliding
- Bug & Bugler Proof Windows
- Slim Interlock Shutter Available for Single Glass & Double Glass Sliding

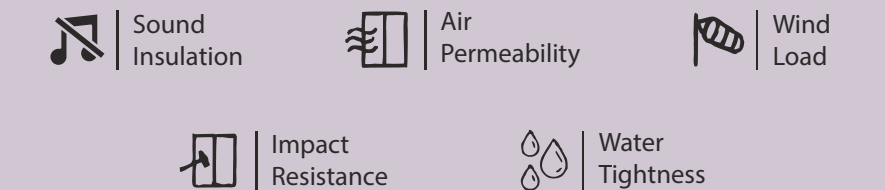



LARGE DOORS
INVITE THE MAJESTY
OF THE OUTSIDE
WORLD,
BRIDGING
VAST SPACES.



TECHNICAL CHARACTERISTICS

Window Height (Max)
3660mm (up to 12ft)

Sash Height & Width
59mm / 35mm

Interlocking
• Slim Interlock 27mm
• Double Interlock

Track Option
• 2 Track
• 3 Track

Track Depth
• 2 Track Top/Bottom 31mm/95mm
• 2 Track Vertical 23mm/100mm
• 3 Track Top/Bottom 31mm/145mm
• 3 Track Vertical 25mm/150mm

Centre Opening
• Possible

Glass Range
• Single Glass Sash 6 to 13.5mm
• Laminated Glass Sash 12 to 14mm
• Double Glass Sash Upto 24mm

Corner Joint
• Track Joint 90 Degree
• Sash Joint 90 Degree .
• Slim Interlock 90 Degree

Roller
Fix Single Roller
Fix Double Roller
Adjustable Double Roller

Locking Options
Single Point & Multipoint

Emerald **VATAYANAM**
Sleek designs, high performance

#superslimseries

The "Emerald" series from Vatayanam is a high-end offering designed for elite architecture, featuring minimal section visibility on all sides to provide a sleek and refined aesthetic.

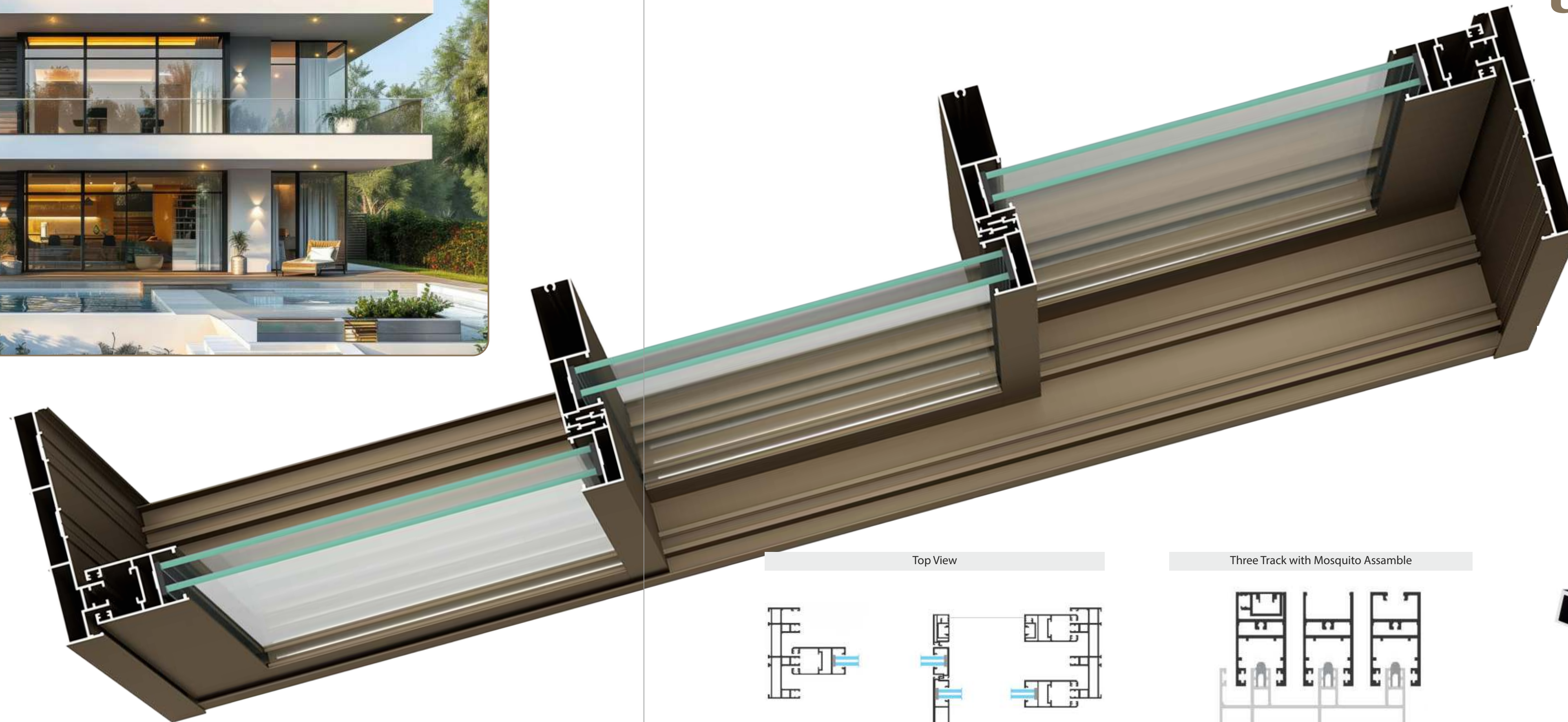

Top View

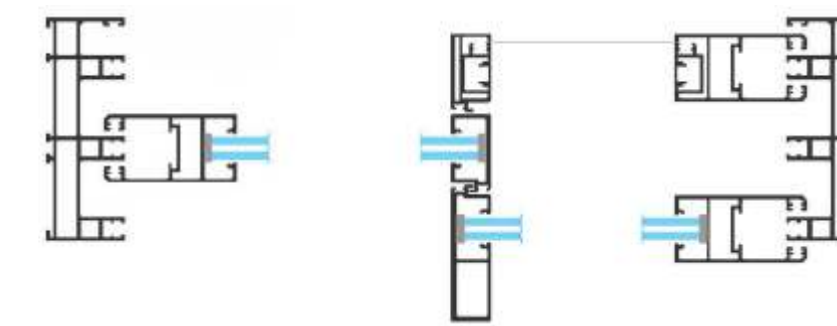

Three Track with Mosquito Assamble

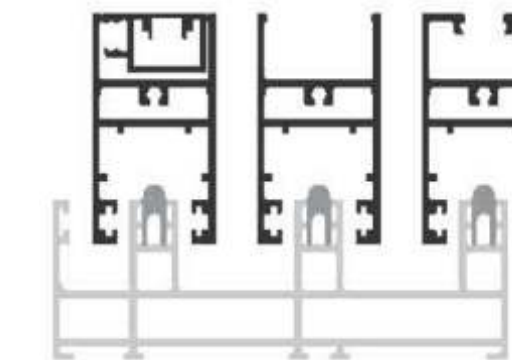



LARGE DOORS
SYMBOLIZE GRAND
OPPORTUNITIES, BLENDING
STRENGTH WITH
TIMELESS ELEGANCE.

Vivid **VATAYANAM**
Sleek designs, high performance

The "Vivid" series from Vatayanam is designed for very large spaces, featuring double-height installations and thicker glass, all flush-fitted to deliver a sleek, modern aesthetic for expansive architectural projects.

Door Height
Max. 4600mm

Sash
Height 4600mm
Width 2500mm

Glass Thickness
Min. 8mm
Max. 26mm

Glass Options
Single/ Laminated
DGU

Lacking Variants
Up Down Lock
180 Lock

Sash Weight
Max 260 kgs

Typologies

V-TECH BUILDING SYSTEMS PVT. LTD.® 15



Top View

Top & Bottom Shutter

Topaz

VATAYANAM
Sleek designs, high performance

The "**Topaz**" series from Vatayanam is designed for all basic openable doors and windows, offering a reliable and functional solution for everyday architectural needs.

KEY FEATURES

- European design, 40mm Casement Series
- Glazing from 5mm to 24mm
- Square Shapes Clip
- Glazing from inside for security
- Corner Joint & T-Joint for stronger Mechanical joinery
- Single Point to Multipoint locking systems
- Smooth & effortless in operation
- Internal & External opening system
- Design for medium opening & mid. wind load condition
- Bugler Proof Windows & Door system

Sound Insulation

Air Permeability

Wind Load

Impact Resistance

Water Tightness

V-TECH BUILDING SYSTEMS PVT. LTD.®

17



Quartz VATAYANAM

Sleek designs, high performance

The "Quartz" series from Vatayanam is a top-end offering for casement windows, featuring sophisticated solutions such as sliding folding doors and tilt & turn windows, providing versatility and elegance for premium architectural designs.

APPLICATION & SECTION DETAILS

SLIDE & FOLD		
SHUTTER* (mm)	HEIGHT	60
FRAME* (mm)	HEIGHT	51
FRAME WIDTH-MIN* (mm)	WIDTH	71
SIGHT LINE FRAME & SHUTTER* (mm)		90
SIGHT LINE AT FOLD* (mm)		128
THRESHOLD HEIGHT AT BOTTOM* (mm)		14

*Above data are for reference purpose only. It is advisable to take prior confirmation from the technical department.

TYPOLOGIES POSSIBLE

KEY FEATURES

- European design, 50mm Casement Series
- Glazing from 5mm to 38mm
- Tilt & Turn system Compatible
- Molding & Square shapes clip
- Glazing from inside for security
- Corner joint & T-Joint for stronger Mechanical joinery
- Single Point to Multipoint locking systems
- Smooth & effortless in operation
- Internal & External opening system
- Design for larger opening & high wind load condition
- Bugler Proof Windows & Door system

Sound Insulation

Air Permeability

Wind Load

Impact Resistance

Water Tightness

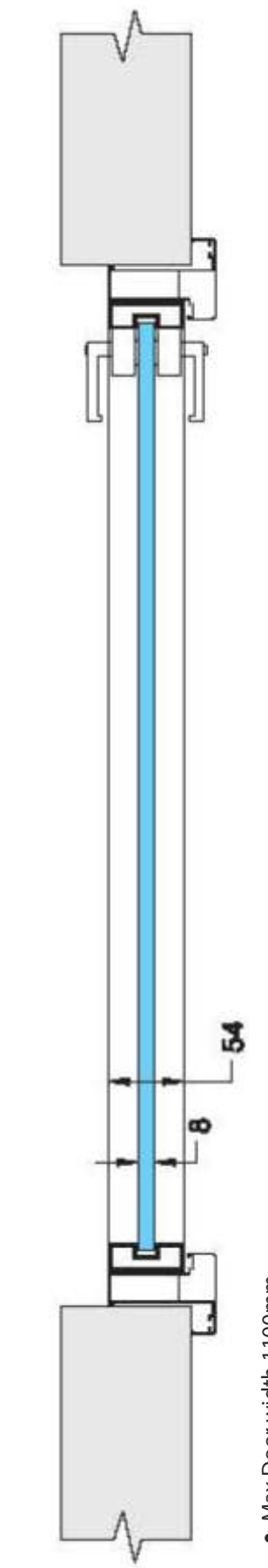

• Max Door width 1100mm
 • Floor Spring to be ordered according to Door height & Door width

Imperial **VATAYANAM**

Sleek designs, high performance

The "*Imperial*" series from Vatayanam is designed to enhance interior spaces, combining aesthetic appeal with user-friendly features to create a harmonious and functional environment.

KEY FEATURES

- Suitable for single or multiple sliding doors.
- Suitable for sliding doors for residences, hotels, office buildings.
- Profile: 16 MM x 45 MM
- Suitable for partition door & sliding
- Can be used for single sliding door, pocket door system, telescopic sliding system, synchronized sliding system for elegant look
- Glass thickness supported: 5 MM and 8 MM
- Min. door width is 790mm
- Max. weight capacity 60 Kg.
- Both side soft close system

Sound Insulation	Air Permeability	Wind Load
Impact Resistance	Water Tightness	

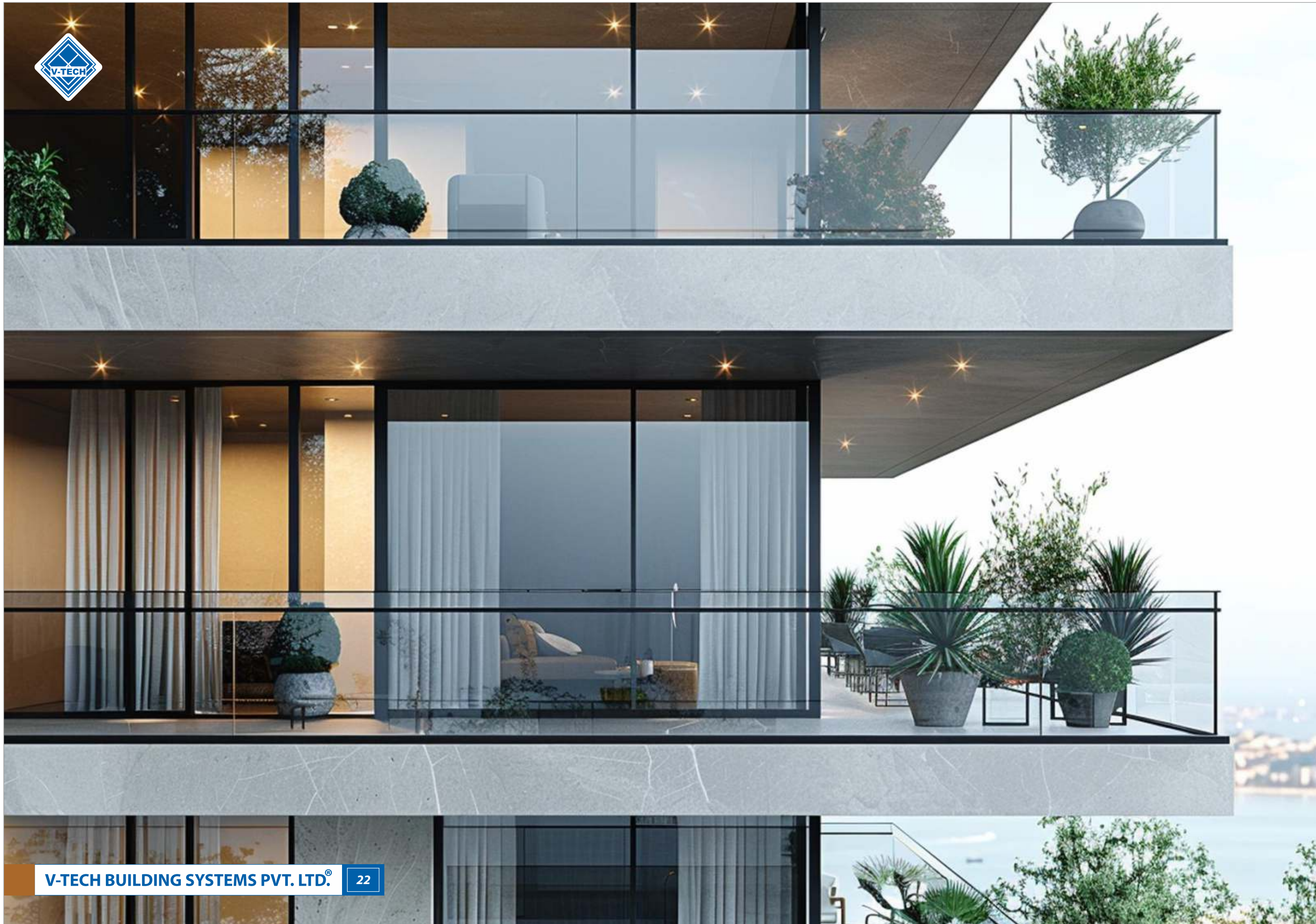

Jett **VATAYANAM**
Sleek designs, high performance

The "Jett" series from Vatayanam is specifically designed for balconies, significantly enhancing the elevation and visual appeal of buildings.

CONTINUOUS RAILING TOP

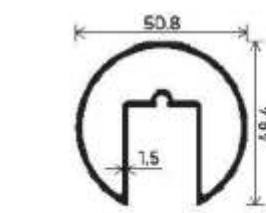

Continuous Railing Top
Section Number: V-10051
Weight (kg/12'): 3.200

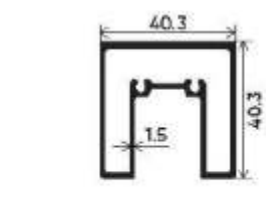

Continuous Railing Top
Section Number: V-10052
Weight (kg/12'): 3.400

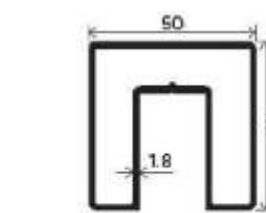

Continuous Railing Top
Section Number: V-10053
Weight (kg/12'): 4.600

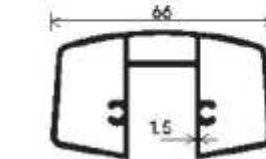

Continuous Railing Top
Section Number: V-10054
Weight (kg/12'): 4.080

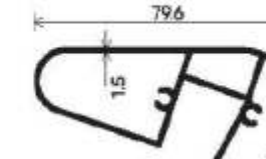

Continuous Railing Top
Section Number: V-10055
Weight (kg/12'): 4.100

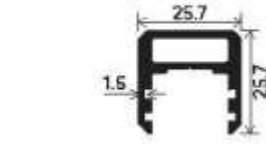

Continuous Railing Top
Section Number: V-10056
Weight (kg/12'): 2.150

CONTINUOUS RAILING BOTTOM

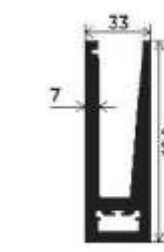

Continuous Railing Bottom
Section Number: V-10001
Weight (kg/12'): 15.775



Continuous Railing Bottom
Section Number: V-10002
Weight (kg/12'): 9.100



Continuous Railing Bottom
Section Number: V-10003
Weight (kg/12'): 14.875

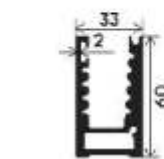

Continuous Railing Bottom
Section Number: V-10004
Weight (kg/12'): 6.850

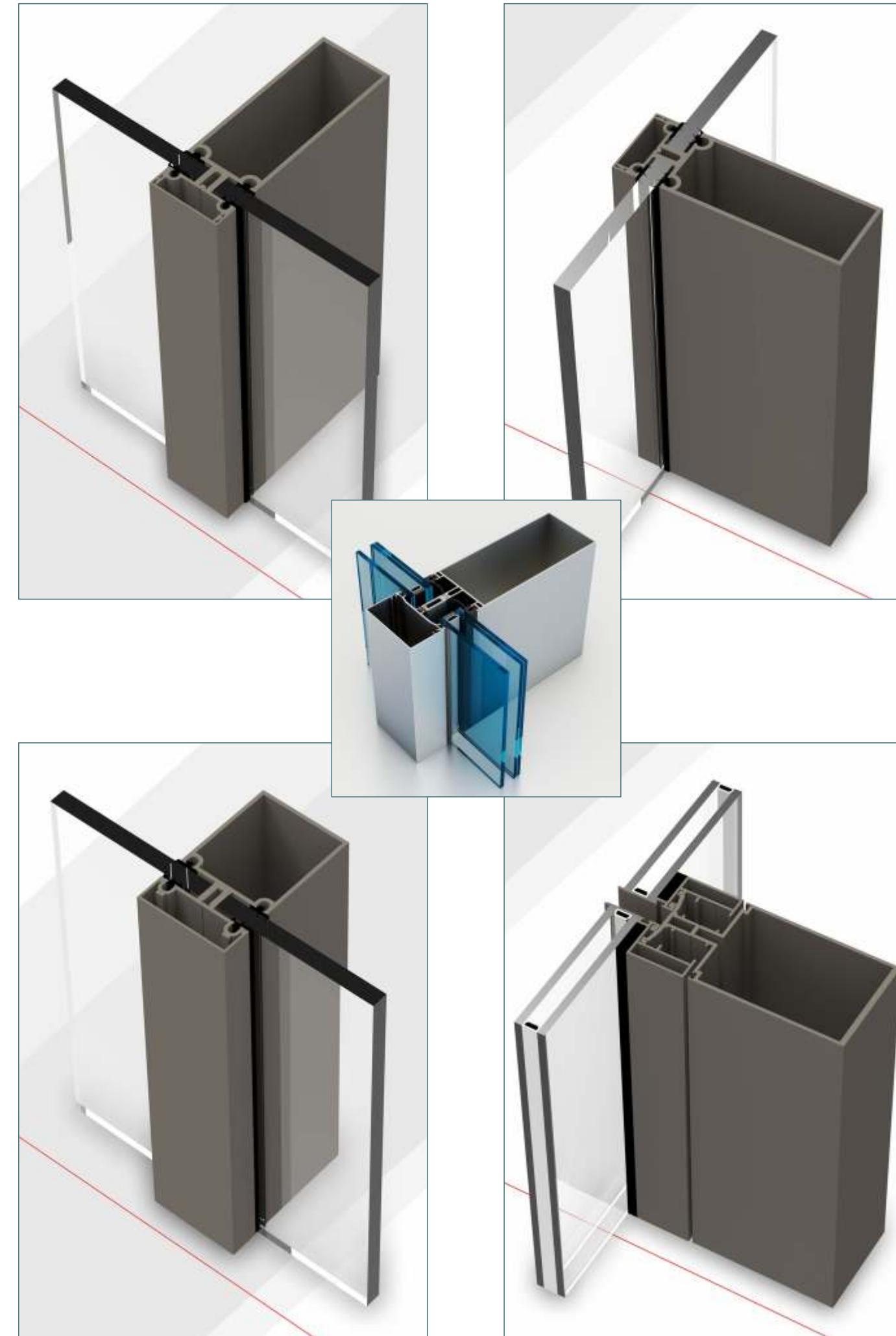

Technical Specification

Window height (Max)
3048mm (Upto 10ft)

Sash Height & Width
73mm & 50mm

Track
Top Load System
74mmx73mm

Bottom Frame
Floor top & Concealed System

Glass Range
Single Glass 6mm to 8mm

Corner Joint
Track Joint 90 Degree
Sash Joint 45 degree

Roller
Top & Bottom Double Roller

Locking System
Multi Point

Louvre Systems have tiny louvre blades and used in smaller size panels with close overlapping.

The louvre blades are assembled with the desired pitch with concealed screws within the screw ribs of the louvre profiles in specially featured vertical channels. The individual assembled panels are fitted in outer frame pockets. Each panel size ranges from 600mm. to 800mm. width to a height of 750mm to 1200mm. These assembled panels shall be fitted in series of openings of the outer frame made of rectangular box section as per individual requirements.

These are normally preferred in interiors, in the facade elements and also as per suggestions of the architects and facade consultants. The system can withstand wind pressure of 1.25kpa. However these technical parameters are to be approved by the consultants from the field depending upon individual merits.

Glazing & Louvre Systems **VATAYANAM**
Sleek designs, high performance

The "Glazing & Louvre Systems" series from Vatayanam is designed for building elevations, creating an architectural envelope that redefines the space, giving it a distinct and transformative identity.

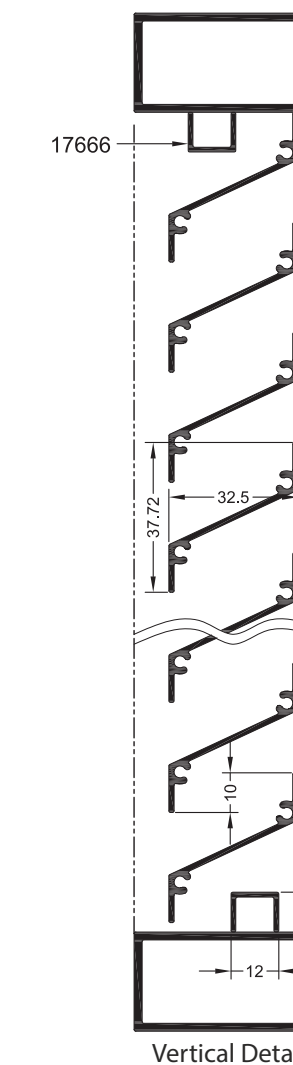
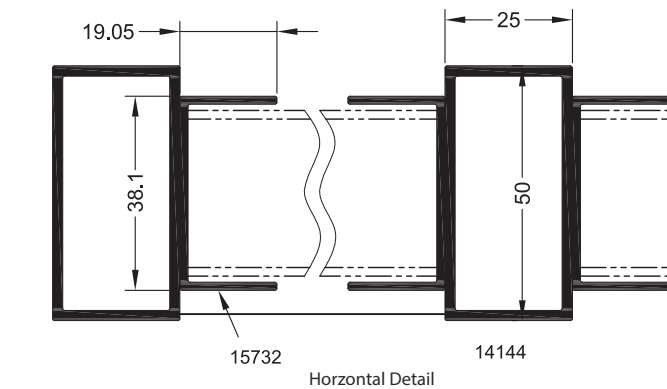
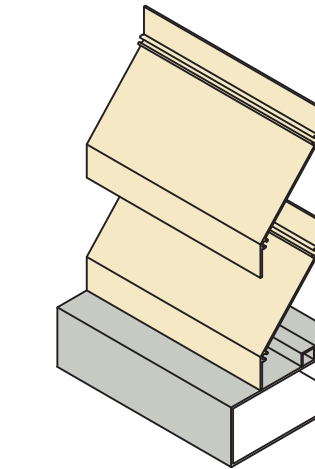
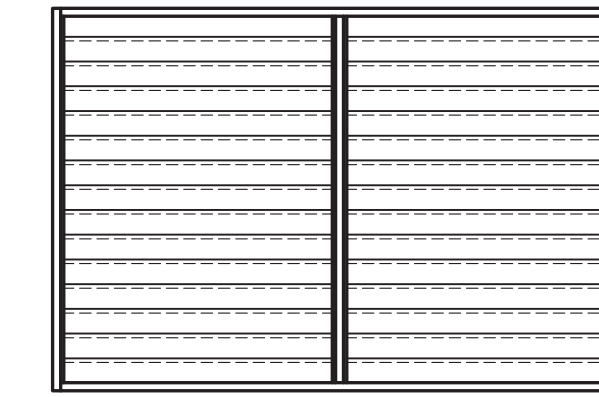

LOUVRE PROFILE		
Section No.	THICK mm.	Weight kg/m
20970	1.29	0.248
21591	2.15	0.610
21713	1.80	0.385

FRAME PROFILE		
Section No.	THICK mm.	Weight kg/m
14144	2.00	0.767
14070	1.47	0.781
14013	2.00	1.054
14029	1.20	0.643

CHANNEL FOR FRAME PROFILE		
Section No.	THICK mm.	Weight kg/m
15732	1.59	0.313

STOPPER PROFILE		
Section No.	THICK mm.	Weight kg/m
17666	1.20	0.245

KEY FEATURES

- European design
- Top sliding system
- Molding & Square shapes clip
- Glazing from inside for security
- Corner joint & T-Joint for stronger Mechanical joinery
- Single Point to Multipoint locking systems
- Smooth & effortless in operation
- Internal & External opening system
- Design for larger opening & high wind load condition
- Bugler Proof Windows & Door system

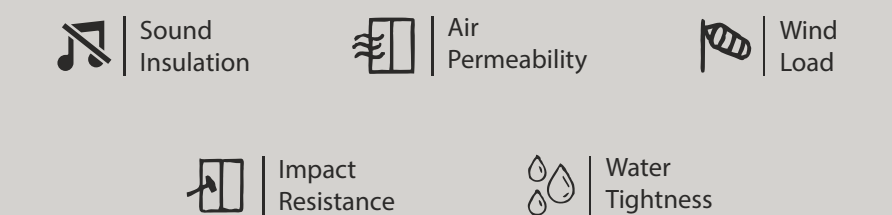



LET YOUR
**DOORS &
WINDOWS**
EXPRESS THIER
OWN BEAUTIFUL
TALE...!

